

PHILIPS

Lighting



MASTERCcolour CDM-Tm Elite Mini

MASTERCcolour CDM-Tm Elite Mini 35W/930 GU6.5 1CT

Mini, single-ended, very high-efficiency, long-life Ceramic Metal Halide discharge lamp producing crisp white sparkling light with high colour rendering

Product data

General Information	
Cap base	GU6.5 [GU6.5]
Operating position	UNIVERSAL [Any/Universal]
Life to 5% failures (nom.)	12000 h
Life to 10% failures (nom.)	14000 h
Life to 20% failures (nom.)	16000 h
Life to 50% failures (nom.)	20000 h
ANSI code HID	C130/E

Light Technical	
Colour code	930 [CCT of 3,000 K]
Luminous flux (rated) (min.)	3600 lm
Luminous flux (rated) (nom.)	4000 lm
Colour designation	Warm white (WW)
Lumen maintenance 1,000 hours (nom.)	95 %
Lumen maintenance 12,000 hours (nom.)	80 %
Lumen maintenance 2,000 hours (nom.)	93 %
Lumen maintenance 4,000 hours (nom.)	90 %
Chromaticity coordinate X (nom.)	0.435
Chromaticity coordinate Y (nom.)	0.396
Correlated colour temperature (nom.)	3000 K

Luminous efficacy (rated) (nom.)	102 lm/W
Color rendering index (min.)	87
Color rendering index (nom.)	90

Operating and Electrical

Power (Rated) (Nom)	39.0 W
Lamp current run-up (max.)	1 A
Re-ignition time (min.) (max.)	15 min
Ignition time (max.)	30 s
Voltage (Max)	95 V
Voltage (Min)	79 V
Voltage (Nom)	87 V

Controls and Dimming

Dimmable	no
Run-up time 90% (max.)	3 min

Mechanical and Housing

Bulb finish	Clear (CL)
-------------	------------

MASTERC colour CDM-Tm Elite Mini

Approval and Application

Energy efficiency label (EEL)	A+
Mercury (Hg) content (nom.)	4.7 mg
Energy Consumption kWh/1000 h	43 kWh

UV

PET (NIOSH) (min.)	8 h/500lx
Damage factor D/fc (max.)	0.4

Luminaire Design Requirements

Bulb temperature (max.)	450 °C
Cap base temperature (max.)	250 °C

Product Data

Full product code	871829115382500
-------------------	-----------------

Order product name	MASTERC colour CDM-Tm Elite Mini 35W/930 GU6.5 1CT
EAN/UPC – product	8718291153825
Order code	15382500
Local Code	CDMTM35930GU651
Numerator – quantity per pack	1
Numerator – packs per outer box	12
Material no. (12NC)	928187405130
Net weight (piece)	0.008 kg
ILCOS Code	MT/UB-35/930-H-GU6.5-13.3/52

Warnings and Safety

- Use only in totally enclosed luminaire, even during testing (IEC61167, IEC 62035, IEC60598)
- The luminaire must be able to contain hot lamp parts if the lamp ruptures
- Use only with electronic control gear
- For 50W use with Philips electronic gear only
- Control gear must include end-of-life protection (IEC61167, IEC 62035)

Dimensional drawing

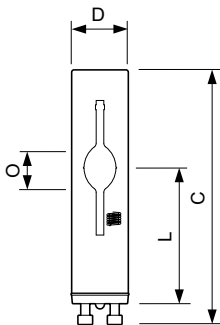

CDM-Tm 35W/930 GU6.5

Product	D (max)	D	O	L (min)	L (max)	L	C (max)
MASTERC colour CDM-Tm Elite Mini 35W/930 GU6.5 1CT	13.3 mm	0.5 in	4.7 mm	28 mm	32 mm	30 mm	56.7 mm

Photometric data

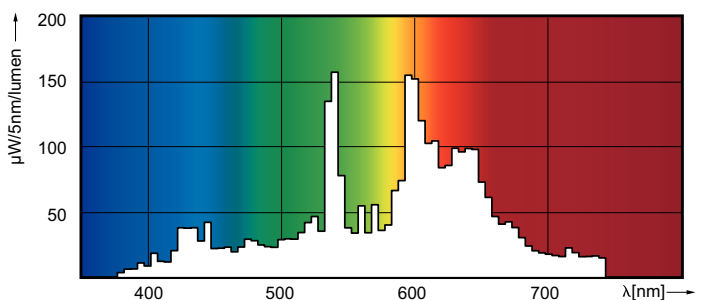
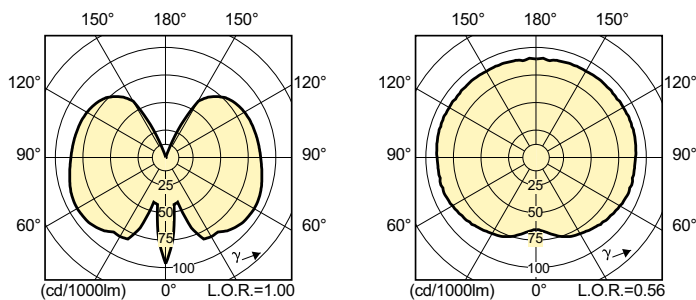

MASTERColour CDM-Tm Elite Mini

Lifetime

