

PHILIPS

Lighting



MASTER MHN-FC

MASTER MHN-FC 1000W/740 230V XW

Compact quartz metal halide lamps with double pinch

Product data

General Information	
Cap-Base	DOUBLEENDED [Double Ended]
Operating Position	P5 [Parallel +/-5D or Horizontal(HOR)]
Life to 5% Failures (Nom)	7000 h
Life To 10% Failures (Nom)	8000 h
Life to 20% Failures (Nom)	9500 h
Life to 50% Failures (Nom)	12000 h
Light Technical	
Color Code	740 [CCT of 4000K]
Luminous Flux (Rated) (Min)	88000 lm
Luminous Flux (Rated) (Nom)	93000 lm
Color Designation	White (WH)
Lumen Maintenance 1000 h (Nom)	90 %
Lumen Maintenance 10000 h (Nom)	70 %
Lumen Maintenance 2000 h (Nom)	85 %
Lumen Maintenance 5000 h (Nom)	75 %
Chromaticity Coordinate X (Nom)	374
Chromaticity Coordinate Y (Nom)	366
Correlated Color Temperature (Nom)	4100 K
Luminous Efficacy (rated) (Nom)	91 lm/W
Color Rendering Index (Min)	62
Color Rendering Index (Nom)	65
Operating and Electrical	
Lamp supply voltage	230 V [230]

Power (Nom)	1040.0 W
Lamp Current Run-Up (Max)	12.5 A
Lamp Current (EM) (Nom)	8.9 A
Ignition Supply Voltage (Min)	198 V
Voltage (Max)	145 V
Voltage (Min)	115 V
Voltage (Nom)	130 V

Controls and Dimming

Dimmable	No
----------	----

Mechanical and Housing

Bulb Finish	Clear
Cap-Base Information	Cable

Approval and Application

Energy Efficiency Label (EEL)	A+
Mercury (Hg) Content (Nom)	85 mg
Energy Consumption kWh/1000 h	1144 kWh

UV

Pet (Niosh) (Nom)	0.049 h.klx
Damage Factor D/fc (Nom)	3.4
Specific Eff. Radiant Power	235 mW/klm

MASTER MHN-FC

Luminaire Design Requirements

Bulb Temperature (Max)	950 °C
Pinch Temperature (Max)	350 °C

Product Data

Full product code	871150021424900
Order product name	MASTER MHN-FC 1000W/740 230V XW
EAN/UPC - Product	8718291548256

Order code	928075705130
Numerator - Quantity Per Pack	1
Numerator - Packs per outer box	1
Material Nr. (12NC)	928075705130
Net Weight (Piece)	140.000 g
ILCOS Code	MD-1000/40/2B-H-XW

Warnings and Safety

Dimensional drawing

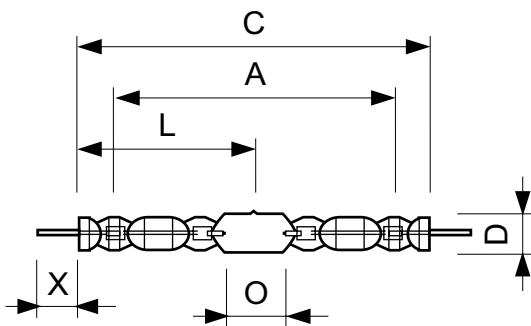

MHN-FC 1000W/740 230V XW

Product	D (max)	D	O	X	L	A	C (max)
MASTER MHN-FC 1000W/740 230V XW	33 mm	25.5 mm	42.5 mm	58 mm	144 mm	226 mm	290 mm

Photometric data

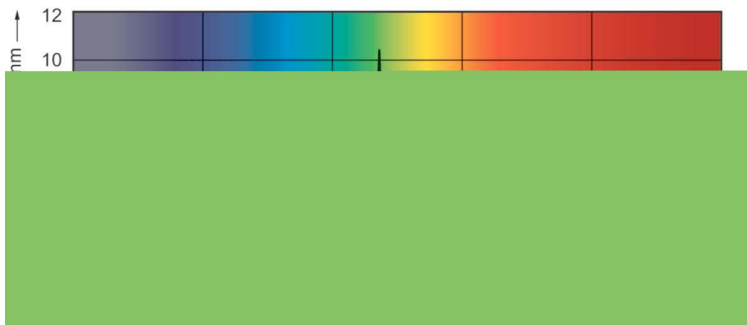

MASTER MHN-FC

Lifetime

